

# Company Presentation



CV EVENT METZINGEN 2026



Das Original

# Contents

**01** **ElringKlinger Group**  
General introduction

**02** **The aftermarket brand**  
Elring – Das Original  
More Product  
More Service



Das Original

# GENERAL INTRODUCTION



Company history



Das Original

**different**  
**Know-how**

TWO COMPANIES WITH COMPLEMENTARY  
EXPERTISE AND VISIONS

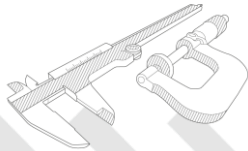
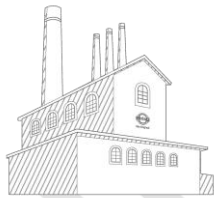

Das Original

MANUFACTURER



ENGINEER

**Combined to become a**  
**Visionary**  
**company**



A VISIONARY WITH A PEDIGREE OF SUCCESS

# Over 145 years of experience



**1879**

Foundation of Elring GmbH in Stuttgart (southern Germany)



**1927**

First series production of seals for trucks  
OM 5 (75Ps) - a significant milestone in engine technology



**1885**



Richard Klinger establishes a design office in Vienna

**1994**

Elring GmbH merges with the Automotive Division of Richard Klinger GmbH to form ElringKlinger GmbH



# Global Overview of Production Sites: More than 40 locations worldwide



Das Original

## NORTH AMERICA

**CANADA**  
Leamington

**USA**  
Plymouth  
Southfield  
Fort Wayne  
San Antonio  
Easley  
Wilmington

**MEXICO**  
Toluca

## SOUTH AMERICA

**BRAZIL**  
Piracicaba

## AFRICA

**SOUTH AFRICA**  
Alberton

## EUROPE

**GERMANY**  
Dettingen/Erms  
Langenzenn  
Runkel  
Geretsried-Gelting  
Lenningen  
Bietigheim-Bissingen  
Heidenheim  
Mönchengladbach  
Rottenburg am  
Neckar  
Neuffen

**GREAT BRITAIN**  
Redcar  
Gateshead  
Solihull

**FRANCE**  
Nantiat  
Chamborêt  
Poissy

**SPAIN**  
Reus

**ITALY**  
Settimo Torinese

**HUNGARY**  
Kecskemét

**ROMANIA**  
Timisoara

**TURKEY**  
Bursa

## ASIA

**PR CHINA**  
Changchun  
Suzhou  
Qingdao  
Tianjin Branch

**SOUTH KOREA**  
Gumi

**JAPAN**  
Gunma  
Tokyo  
Saitama

**INDIA**  
Ranjangaon

**INDONESIA**  
Karawang

**THAILAND**  
Bangkok



# In a nutshell



Das Original



Around **8,700** employees  
as of September 30, 2025



Family as a  
**strong anchor**  
shareholder



Headquartered in  
**Dettingen/Erms,**  
close to Stuttgart



**1,803 Mio. EUR**  
2024 in Sales



Around **40** locations  
worldwide in **19** countries



Founded in  
**1879**

The Aftermarket Brand



Das Original

# Elring – Das Original



# Etring product range for CV

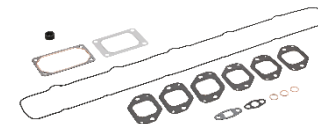
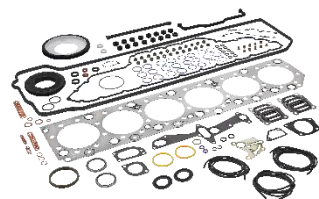
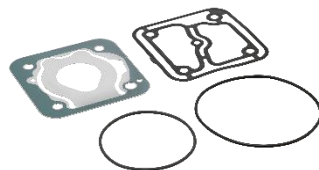
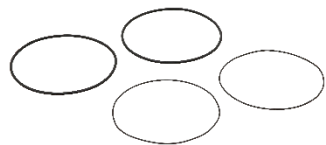
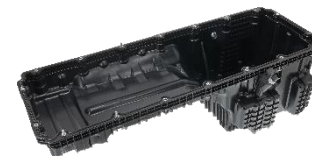
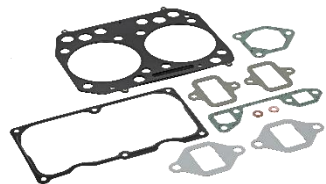
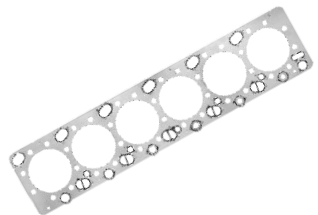

# Our comprehensive GASKET solutions



Das Original



## WIDE RANGE

We supply gasket and gasket sets for a wide variety of truck models and engine types.

## PROVEN PERFORMANCE

Our gaskets are designed for long-lasting performance and high quality. They meet all market needs.

## OEM QUALITY

ELRING gaskets are made by ElringKlinger – the company that works closely with almost all vehicle and engine manufacturers worldwide as a development partner, from the initial idea to series production.

# Historical Milestones: Evolution of Cylinder-Head Gaskets



- Static systems with surface pressure
- Asbestos-based and later asbestos-free gaskets
- Engine power up to 150 kW, combustion pressure up to 120 bar
  
- Dynamic Sealing Systems for Higher Performance
- Introduction of Euro 4/5
- Single-layer metal-elastomer gaskets
- Performance up to 450 kW, turbocharging
  
- State-of-the-art, multi-layer systems with insert technology
- Euro 6 standards
- Performance up to 500 kW, max. combustion pressure 250 bar

1950

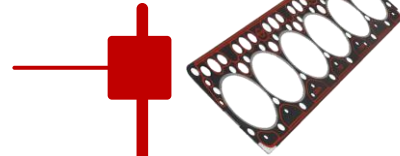

1970



1992



2011



**long-lasting, high-performance gaskets for a range of applications!**

# Key truck brands and models



Das Original

## Mercedes-Benz

- OM 457 LA
- OM 460 LA
- OM 501 LA
- OM 502 LA
- OM 904 LA
- OM 906 LA
- OM 924 LA
- OM 926 LA
- MDEG
- HDEP



## MAN

- D20/D26 series
- D2866/D2876 series
- D38 series
- D1556
- Off-highway



## Scania

- DC 9
- DC 12
- DC 13
- DC 16



## Iveco

- Cursor Series
- Tector Series



## Volvo

- D13
- D16
- D11
- D8



## DAF

- PACCAR MX-13
- PACCAR MX-11
- PACCAR PX-7



## Cummins

- ISC
- ISL
- ISX
- QSX



The Aftermarket Brand



Das Original

**MORE PRODUCT**



# MAN Gasket, cylinder-head for ENGINE REPAIR



**Thickness of 1.5 mm!**

Standard cylinder-head gaskets: thickness of 1.2 mm (Elring no. 021.262 or 357.831)

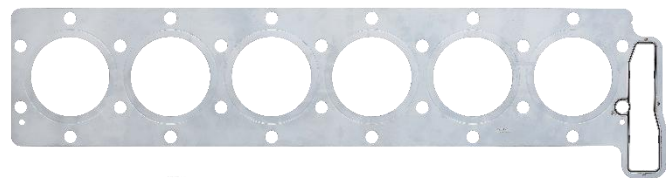

D 20  
195.470

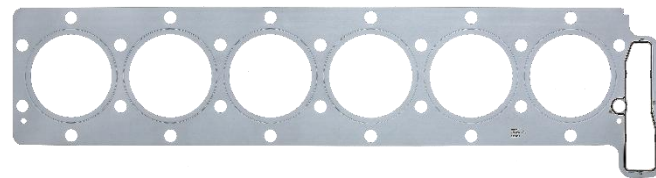

D 26  
466.600

# MAN – Highlights



Das Original



765.520



563.990

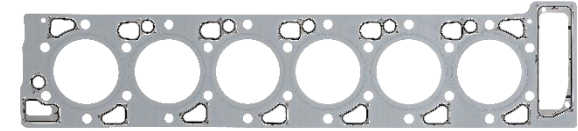

631.741

## D2676 EVO

EVO version: Enhanced cylinder-head gasket with relief slots and advanced combustion chamber stopper technology

## D3876

- Heavy-duty 6-cylinder, 15.3 L (up to 640 HP), Off-Highway D4276 (16.2 L, up to 790 HP)
- Cylinder-head gasket with fire rings for extreme pressure and temperature
- Top-down cooling requires specialized coolant gaskets

## D1556

- Compact 6-cylinder, 9.0 L, up to 440 HP
- Gaskets made from high-temperature elastomers and metallic components for harsh off-road and industrial use

# DAF PACCAR: MX-11



On the market since 2014 - Installed in several thousand vehicles

- **DAF PACCAR**
  - CF, XF, XG, XG+, XD (220 - 330kW)
- **Solaris**
  - Urbino 18
  - Urbino mh
- **Kenworth | Peterbilt:**
  - Kenworth T680/T880
  - Peterbilt 579/567
- **City buses and special vehicles**

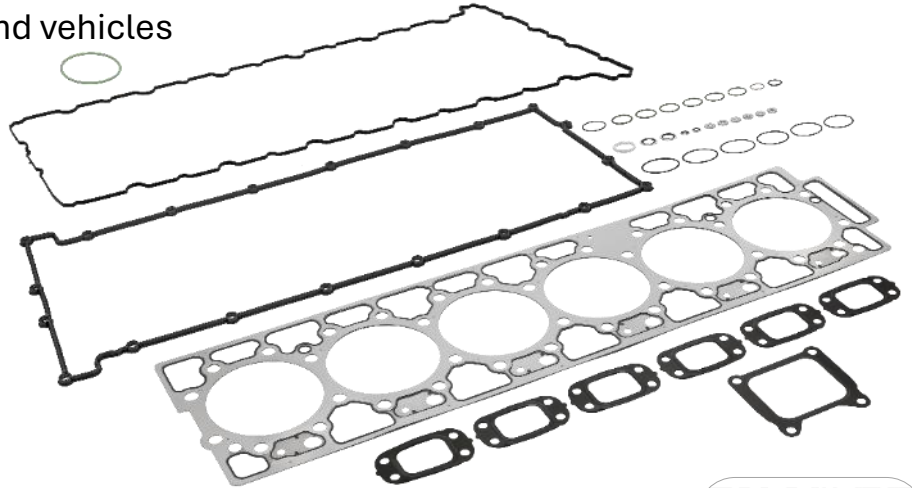

SCAN  
ME!



New

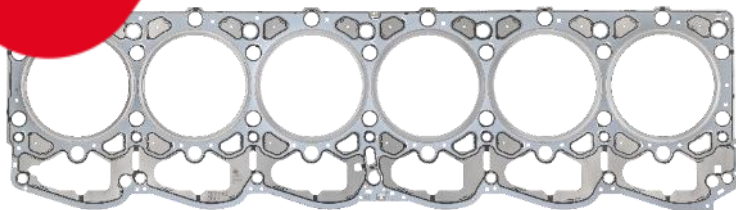

Service cylinder-head gasket

Elring no. 461.881

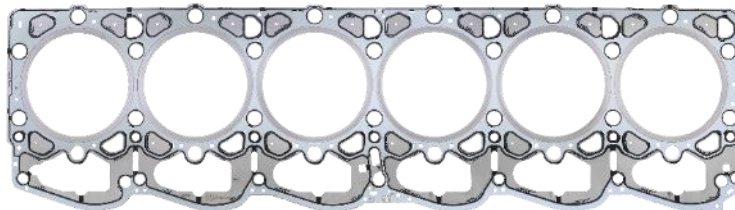

Standard cylinder-head gasket

Elring no. 575.043

## Important for Repairs

If there is damage to the cylinder-head sealing surfaces:

Use service cylinder-head gasket Elring 461.881

- Specially adapted sealing profile
- Partially profiled for long-lasting sealing

# DAF PACCAR: MX-13 from model year 2021

## Gasket, Cylinder-head

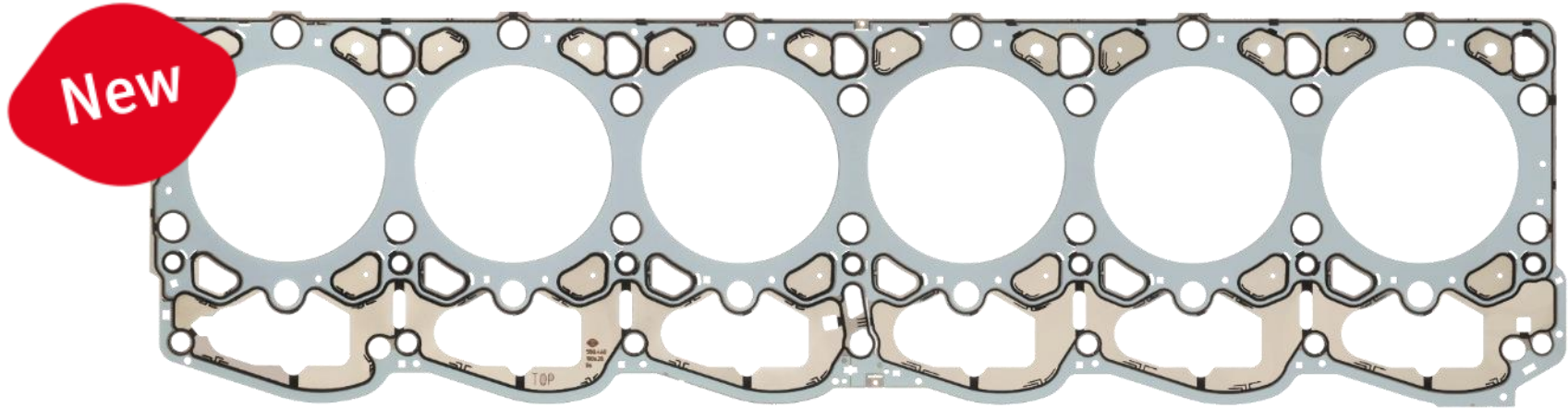

MX-13 from model year 2021  
Elring no. 550.460

# Mercedes-Benz OM 934/936



Das Original

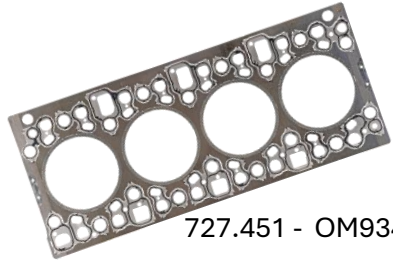

727.451 - OM934 | DD5

- Designed to replace the OM 926 engine series
- Four/Six-cylinder inline engines with a displacement of 5.1 / 7.7 Liters

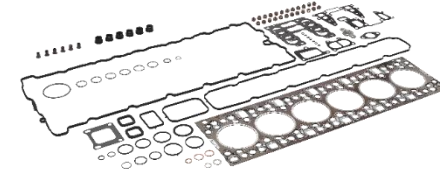

822.520 - OM936 | DD8

## Environmental Compliance

- compliant with **Euro VI** emissions standards
- **Advanced combustion system** for lower emissions and higher efficiency
- **First series-**produced diesel engines with a **variable exhaust camshaft** → higher exhaust temps, improved DPF regeneration

## Efficiency

- Durable Design **with low fuel consumption**, AdBlue and oil consumption
- **Long service intervals** up to 120.000 km under high-duty operation a 20% increase over the previous generation, accompanied by a 12% reduction in oil fill volume

## High Performance

- Reaching Performance **comparable to larger engines**: Specific power output of up to ~34 kW (46 hp) per liter of displacement
- **Excellent Drivability**: 90% max engine power 1600 & 2500 rpm
- **Enhanced engine brake** for higher safety and transport efficiency

# Mercedes-Benz HDEP – Oil cooler sets



Das Original

## Design and Function

- liquid-cooled oil cooler
- **High heat transfer performance** especially under continuous duty conditions
- **Stable oil temperature**
- **Independence from external airflow**

## HDEP Platform Integration

- Oil Coolers feature a **modular design**
- Part of the **HDEP Component System**
- **Engine-specific sealing kits** available precisely matched to the respective assembly

## System Integration

- integrated into the **lubrication and cooling circuits**
- **Mounted on the engine block side** within the oil module
- **Heat transfer** against the engine coolant (cooling-water circuit)

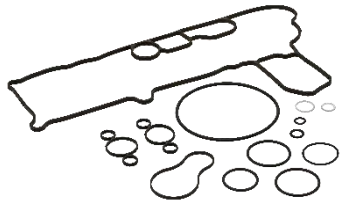

840.740, OM470

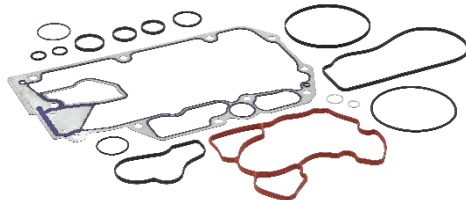

840.871, OM471

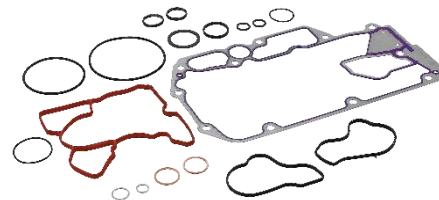

164.820, OM 472

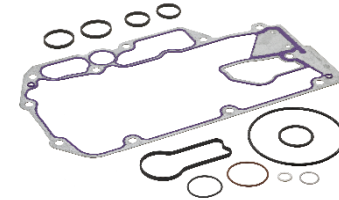

841.330, OM473

# Spare Parts Portfolio Expansion: First CV Plastic Oil Pan suitable



## Compatible with a Wide Range of Vehicles

The new **plastic oil pan B36.520 for the Mercedes-Benz OM 471** is compatible with numerous vehicle models, covering a broad spectrum of **commercial vehicles and coaches:**

**Actros MP4 & MP5**  
**Antos**  
**Arocs**  
**Travego**

New

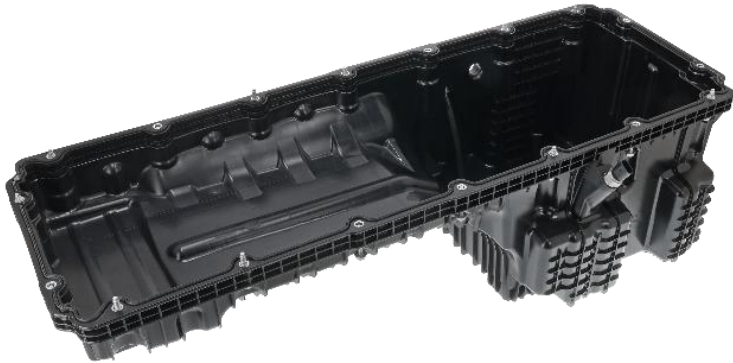

# Cummins ISX15 and X15 Engines Cylinder-head gasket



- **CM570 (up to 27.08.2001 or Serial number up to 14022615):**

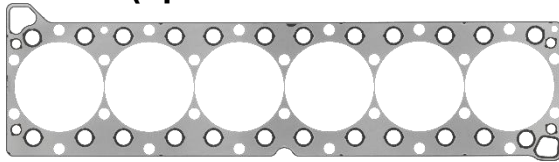

140.230,



6x 140.200,



6x 140.120

- **From 28.08.2001 or Serial number 14022616, also CM870 and CM871 (EPA07):**

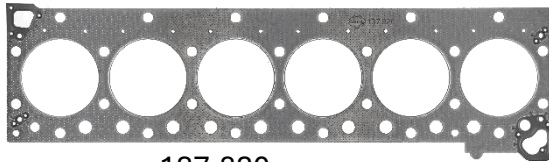

137.820

- **CM2250 (EPA10) and CM2350 (EPA13):**

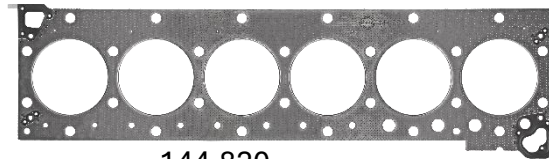

144.820





Elring offers one of the most comprehensive aftermarket portfolios for Chinese commercial vehicles in OEM quality. With more than **32,000** vehicle linkages and over **600** part numbers!

## Coverage of key engine families

- Foton: ISF2.8/3.8, ISB4.5/6.7, ISL8.9/9.5, ISLe290-380, ISM11, ISX15
- Weichai/Sinotruk: MC05, MC07, MC11, MC13, WP4, WP6
- FAW: CA4DD1, CA4DD3, CA6DK1
- Jiefang (FAW) : BF4M1013, BF6M1013, BF4M2012
- JAC: 4JJ1, HFC4DA1-2C, AC - 4JJ1GD

# Extending our Industrial Portfolio & Updated Catalog



New



MAN  
Deutz/MWM  
MTU  
Doosan  
Jenbacher  
Cummins  
Siemens/Guasc  
or  
Liebherr  
Scania

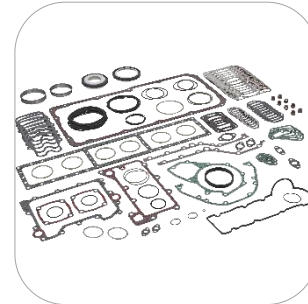
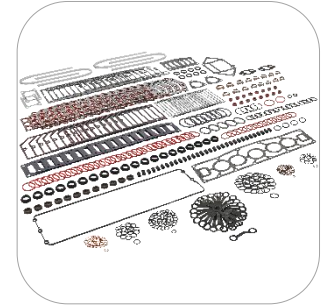

# Tailored for Off-Highway, Portfolio Extensions



Das Original

New



## Perkins / Caterpillar

1104 A-C\*  
1004 \*  
1106 \*  
C4.4 ACERT, C6.6  
ACERT

## Cummins

X12 + ISX12 (11.9 ltr.)  
X15 + ISX15 (14.9 ltr.)  
L9 (8.9 ltr.)  
ISB (6.7 ltr.)

## Deutz

TCD 2.9  
TCD 3.6  
TCD 7.8  
TCD 2012

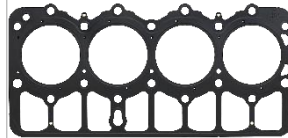

## John Deere PSS

(4.5 ltr.)  
(6.8 ltr.)  
(9.0 ltr.)  
(13.5 ltr.)

SCAN  
ME!



The Aftermarket Brand



Das Original

# MORE SERVICE



## Keep up-to-date and never miss a thing:



### Newsletter

Tips from the professionals direct to your inbox.



### Service Hotline

How can we help?



### Elring Sealants Adviser

Simple steps to the right product.



### Mediacycenter

All publications, videos, TSI & VSI documents.

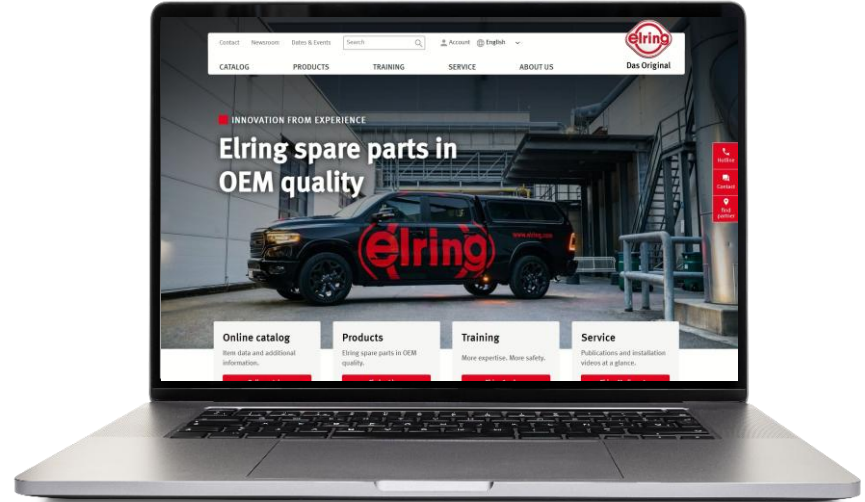

MORE INFO



# Exploded view drawings



Das Original

r  
nes



S



Das Original

Gaskets and Gasket sets suitable for

BMW | MINI  
B48

The BMW B48 is a 2.0 litre in-line four cylinder turbo engine that has been in production since 2014. It offers up to 250 horsepower and 420 Nm of torque. The engine is characterized by its efficiency and environmental friendliness, meeting Euro 6 standards and being used in various BMW and MINI models. The B48 features direct fuel injection, variable valve timing (Valvetronic) and camshaft adjustment. It is known for its reliability and performance. The engine block is made of aluminum, which reduces weight and improves heat dissipation. The B48 is also known for its adaptability to different driving conditions and its durability.

[www.elring.com](http://www.elring.com)



Coding

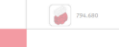

ElringKlinger AG | Altemmelster Strasse  
Max-Planck-Strasse 2 | 37075 Göttingen, Germany  
Fax: +49 531 732 724 299 | Tel: +49 531 732 724 298  
service@elring.de | www.elring.com



Das Original



Das Original

Mercedes-Benz

OM 471

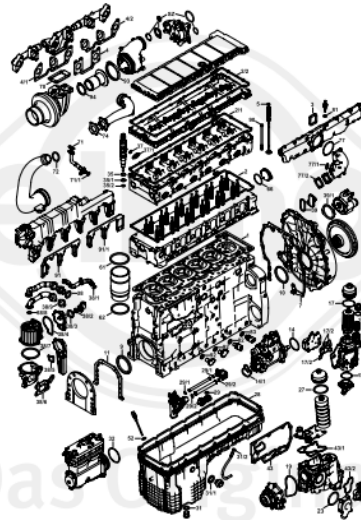

Das Original



Elring-Service



Das Original



The new high-performance adhesives have

Elring is expanding its chemical product portfolio to enable strong and durable connections. These new products are designed for the repair and bonding of metal and plastic components of other manufacturers.

Lightfast products from Elring impress with their high resistance to the chemical reaction of the new components. Both products offer further processing. They are suitable for a wide range of materials and are resistant to various chemicals and environmental influences.

**Lightfast Plastic** - The fast-curing 2-component polyurethane

Lightfast Plastic is a fast-curing polyurethane based 2-component adhesive for repair of plastics in the automotive and industrial sectors. The adhesive is also suitable for gluing or filling hollow plastics, e.g. PMMA, ABS, PC, PVC, PA6, PA66, PP, PE, CFRP, carbon fiber and certain metals.

**The advantages of Lightfast Plastic at a glance:**

- No hazardous license required for the user!
- Fast curing and high glue filling capacity up to 30 mm
- Can be repaired and painted over
- Impact resistant adhesive
- Resistant to oil, weathering and aging
- Resistant to water, wet water, steam, oil and mechanical stress

**Lightfast Metal** - The 2-component epoxy resin based

Lightfast Metal is a 2-component epoxy resin adhesive with excellent adhesion to metals such as iron, steel, cast iron, aluminum, wood and many types of plastic. Lightfast Metal is suitable for filling, sealing and repairing cracks, holes, inclusions and defects in metal parts.

The adhesive is suitable for repairing metal parts such as engine components. Typical application examples include: the repair of exhaust systems, housings, manifolds or car components.



The new high-performance two-component adhesives have arrived

Etring is expanding its chemical product portfolio to include 2-component adhesives that enable strong and durable connections. These new products have been specially developed for the repair and bonding of metal and plastic parts, but are also suitable for a variety of other materials.

**Lighth Plastic** – The fast-curing 2-component polyurethane adhesive  
 Lighth Plastic is a fast-curing polyurethane based 2-component adhesive for structural and cosmetic repair of plastics in the automotive and transport sector. The adhesion is also suitable for gluing or filling holes, cracks and joints of plastic parts (e.g. PMMA, ABS, PC, PVC, PA6, HDPE, PE, SPS, rubber elastomers, as well as wood, stone, glass and certain metals).

The advantages of Lighth Plastic at a glance:

- No isocyanate license required for the user!
- Fast curing and high gap-filling capacity (up to 30 mm)
- Can be reworked and sanded away
- Impact resistant adhesive
- Resists to UV, weathering and aging
- Resists to water, salt water, coolant, oil and many chemicals and even to fuel to a limited degree

**Lighth Metal** – The 2-component epoxy resin based liquid metal mass

Lighth Metal is a 2-component epoxy resin adhesive and impregnate with its excellent adhesion to metals such as iron, steel, cast, aluminium, as well as concrete, wood and many types of plastic. Lighth Metal is therefore ideal for filling, bonding or gluing cracks, holes, incorrect drilling and filling blowholes.

The adhesive is suitable for repairing metal parts such as brackets, pipes, valves and engines. Typical application examples include: Scar panels, bumpers, splines, ventilation systems, housings, wheels or castings, signs and displays.

New



elring  
Das Original

## Etring's Range for Cummins Heavy-Duty Engines



8.3 to 14.9 Liters



Das Original

Gaskets and Gasket sets suitable for

BMW | MINI  
B48

The BMW B48 is a 2.0-litre in-line four-cylinder turbo engine that has been in production since 2014. It offers up to 253 horsepower and 400 Nm of torque. The engine is characterised by its efficiency and environmental friendliness, meeting Euro 6 standards and being used in various BMW and MINI models. The B48 features direct fuel injection, variable valve timing (Valvetronic) and camshaft adjustment. It is known for its reliability and performance. The engine block is made of aluminium, which reduces weight and improves heat dissipation. The B48 is also known for its adaptability to different driving conditions and its durability.

[www.elring.com](http://www.elring.com)



Coding



016.620

044.675

048.700



137.000  
111 112 0 044 016  
M10x1.500

076.475

076.480



076.475  
111 112 0 044 075  
M10x1.500

076.380  
M10x1.500

076.460

076.600

EtringStäger AG | Aftermarket Division  
 Max-Planck-Strasse 2 | D-77761 Dirmingen, Baden-Württemberg  
 Tel: +49 7723 776-199 | Fax: +49 7723 776-794  
 service@elring.de | www.elring.com



Das Original



Chevrolet



Das Original

# Catalogues



Das Original

...al has been in produc-  
torque. The engine is  
...nting Euro 6 stan-  
...All features direct fuel  
...nent. It is known for  
...imum, which reduces  
...y its adaptability to

www.elring.com

644.970    648.100  
796.860    796.800

elring Das Original



Chevrolet

L5P (from 2017)  
L5D (from 2019)

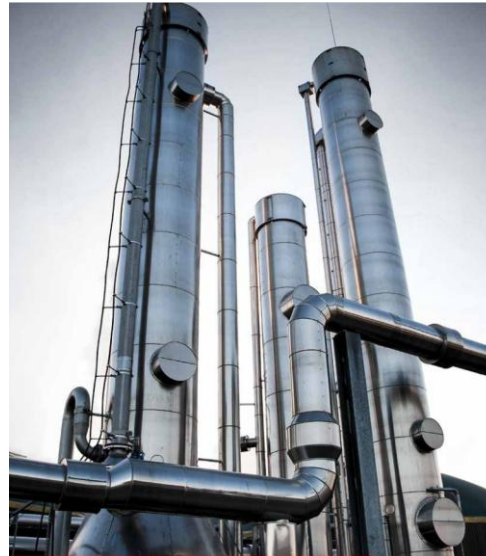
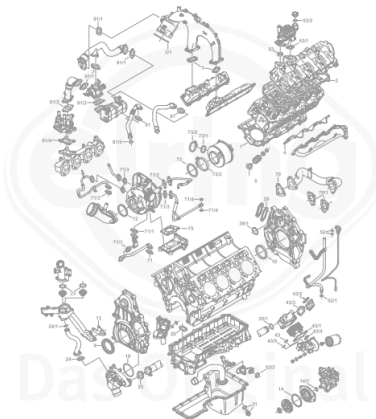

Elring-Service



Das Original



The new high-performance two-component adhesives have arrived

Elring is expanding its chemical product portfolio to include 2-component adhesives that enable strong and durable connections. These new products have been specially developed for the repair and bonding of metal and plastic parts, but are also suitable for a variety of other materials.

Elring products from Elring impress with their high strength and rapid curing thanks to the chemical reaction of the two components. Both products impress with the possibility of rapid further processing. They are suitable for a wide range of applications and offer resistance to various chemicals and environmental influences.

**LiqPrep Plastic – The fast-curing 2-component polyurethane adhesive**

LiqPrep Plastic is a fast-curing polyurethane-based 2-component adhesive for structural and cosmetic repair of parts in the automotive and transport sector. The adhesive is also suitable for gluing or filling holes, cracks and joints of plastic parts (e.g. ABS, PC, PA, PP, PE, PU, PVC, carbon fibre-reinforced), as well as wood, stone, glass and certain metals.

**The advantages of LiqPrep Plastic at a glance:**

- No occupational licence required for the user
- Fast curing and high gap filling capacity (up to 50 mm)
- Can be reworked and painted over
- Impact resistant adhesive
- Resistant to UV, weathering and ageing
- Resistant to water, salt water, coolant, oil and many chemicals and even to fuel to a limited degree.

**LiqPrep Metal – The 2-component epoxy resin based liquid metal**

LiqPrep Metal is a 2-component epoxy resin adhesive and impresses with its excellent adhesion to metals such as iron, steel, cast, aluminium, as well as concrete, copper, wood and more types of plastic. LiqPrep Metal is therefore ideal for filling, bonding or gluing cracks, holes, inclusions pitting and filling blowholes.

The adhesive is suitable for repairing metal parts such as housings, pipes, valves and engines. Typical application examples include: door panels, bumper splitters, ventilation systems, housings, moulds or castings, signs and displays.



Das Original

Elring's Strong  
Cummins  
Heavy-Duty Eng



8.3 to 14.9 Litre

New



Tech Talk is Elring's **video format** for workshops and engine professionals. In short, practical clips, our experts share tips, tricks, and solutions for engine technology – from radial shaft seals to surface finishing.

### Where to find Tech Talk?



YouTube, Instagram, Facebook, WeChat.

### And here's the extra value:

We also provide these Shorts for you to publish on your own channels, making it easy to share high-quality technical content with your audience.

# Stay Connected!



Das Original



#stayontrack @elring\_official



Follow Elring live worldwide!  
@elringdasoriginal



Installation videos for every occasion.  
@elringdasoriginal

Stay up to date with the **latest insights**,  
**product innovations**, and **technical tips**  
– directly from Elring.

**Follow us now** and become part of  
**the Elring community!**

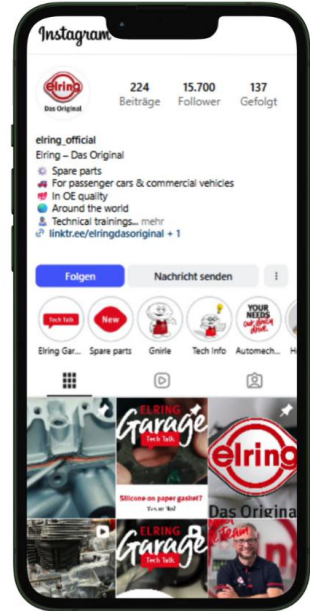

# Elring Trainings



Das Original



Webinars

Training Truck

Company Tours

Elring Sealing Summit

Technical Trainings



# Annual Elring Sealing Summit (ESS)



Das Original

Exclusive event aimed at sharing **Elring's expertise in sealing technology** and **strengthening relationships** with our **partners**.

Including a **factory tour** at our headquarters in Dettingen, **lectures on sealing technology** and an **intercultural program**.

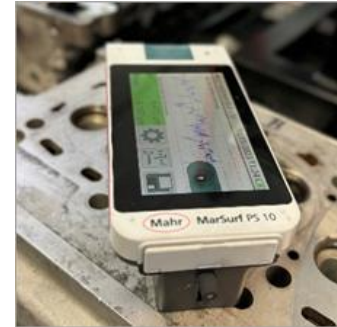

# Elring Akademie 2.0: Expanding the Learning Platform and Providing Structured Modules

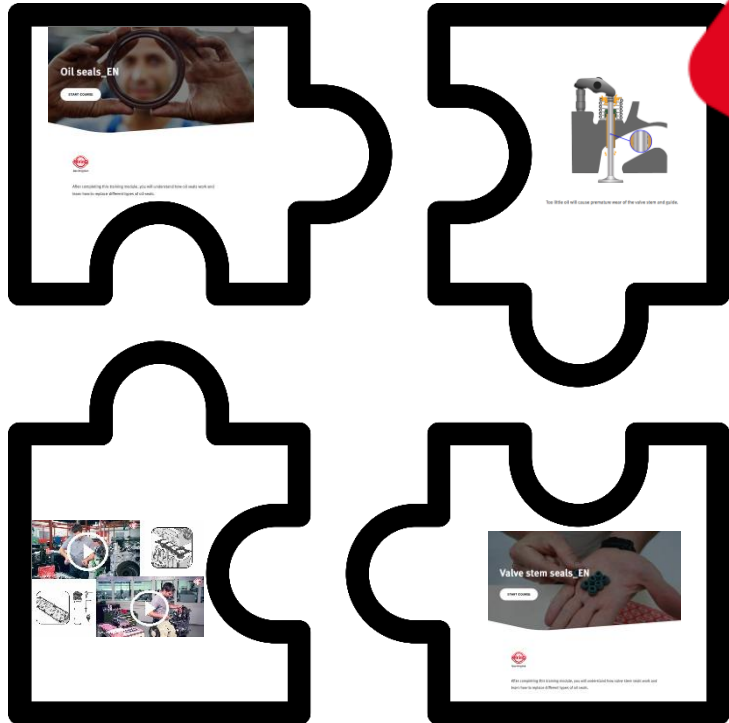

New

**SCORM-Compatible Content:** Our courses are provided in SCORM format – the standard for e-learning platforms.

**Easy Integration:** You can upload the content directly into your own academy or LMS (Learning Management System).

**Modular Building Blocks:** We provide individual learning modules so you can flexibly combine and adapt them to your needs.

**Your Brand, Your Platform:** Use our content under your brand.

We sincerely appreciate the positive and fruitful collaboration we have shared.



Das Original

**THANK YOU**  
*for your attention*

