

Gaskets and Gasket sets suitable for Citroën | Peugeot EBO

The EB engines are three-cylinder in-line engines that have been produced under the PureTech name since 2012. They replace the 1.1-litre and 1.4-litre models of the TU engine.

The first versions to be launched on the market were naturally aspirated engines.

Later versions with turbochargers and intercooling were added.

In the design, great emphasis was placed on reducing the friction of the moving parts by using piston pins, sealing rings and tappets with DLC friction linings. In addition, the new dual-circuit cooling system was introduced. The engine has two overhead camshafts and variable valve timing. Also worth mentioning is the cylinder-head with integrated exhaust manifold.

www.elring.com



Catalog

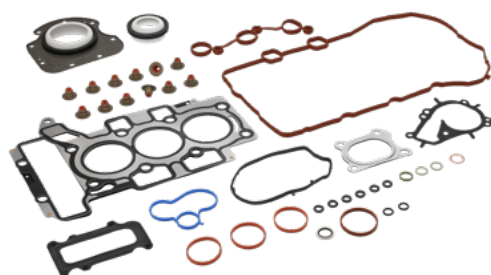

928.980

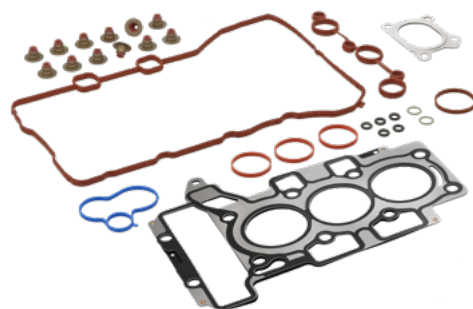

642.530



592.640
#16 083 781 80
M10x1,5x73
M10x1,5x126
M8x1,25x35



779.190

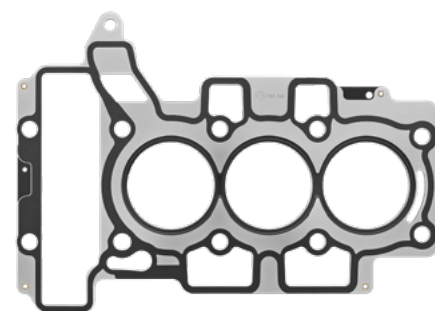

592.540
96 761 487 80
+0,72 | 3-layer

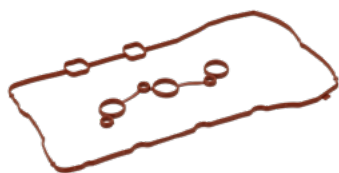

634.660
#96 778 553 80

ElringKlinger AG | Aftermarket Division

Max-Eyth-Straße 2 | D-72581 Dettingen/Erms

Fon +49 7123 724-799 | Fax +49 7123 724-798

service@elring.de | www.elring.com



Das Original

							
	B13.430		582.530 #16 115 102 80 5x9/14,2x14 FPM		577.650 #16 095 876 80 ACM		004.450 #0514.C8 PTFE
							
	707.350 #16 111 874 80 LD		893.889 #1 280 210 752 FPM		577.630 #16 087 337 80		598.610 #96 880 312 80
							
	813.052 16x22x2 CU		036.164 Dirko HT 70 ml		577.610 #98 015 968 80	Engine flyer Citroën Peugeot Fiat Jeep Toyota Opel EB2	